

### Pump Model CPS 400-350-510

**Speed 1450rpm**

0 2000 4000 6000 8000 10000 12000 14000 Q [US GPM]

0 2000 4000 6000 8000 9000 10000 Q [LM GPM]

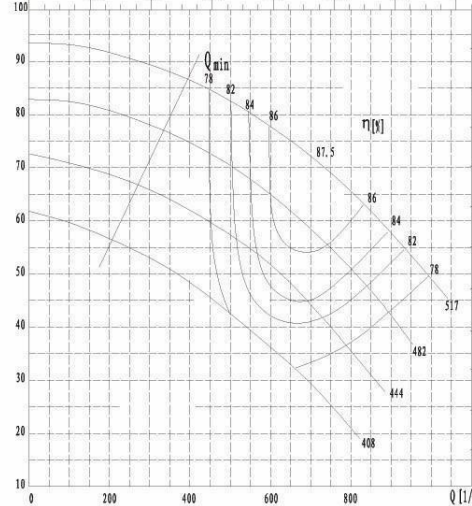

H [ft]

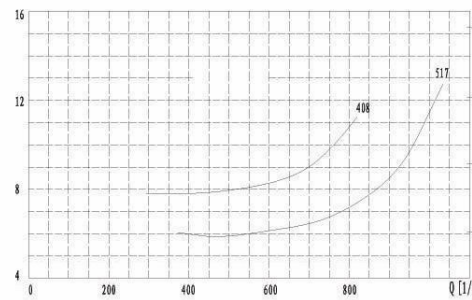

NPSH [ft]

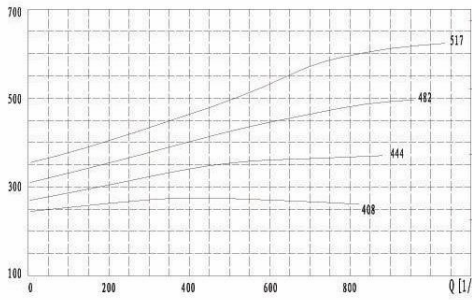

P [hp]

0 400 800 1200 1600 2000 2400 2800 3200 Q [m³/h]

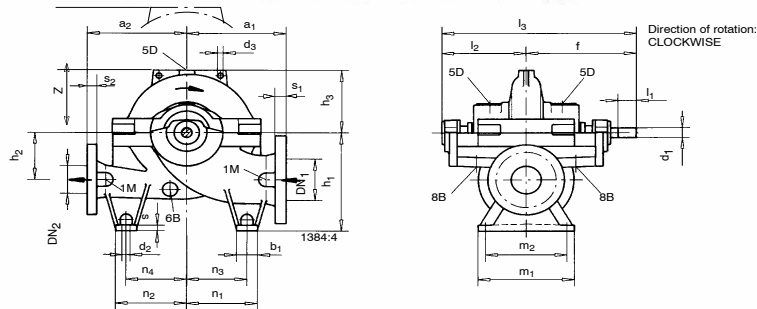

Pump Size	FLANGE DIMENSIONS				PUMP DIMENSIONS									
	DN1	DN2	s1	s2	a1	a2	d3	f	h1	h2	h3	l2	l3	z
CPS 400-350-510	400	350	38.1	36	700	650	24.5	810	750	400	420	585	1395	840
	FOOT DIMENSIONS								SHAFT			PUMP WEIGHT		
	b1	d2	m1	m2	n1	n2	n3	n4	s	d1	L1	(kg)		
	100	22	600	520	525	525	475	475	26	85	180	1395		